

RK3399_Rock960_V2.0

CONTENT INDEXING

- 01.Index
- 02.Change List
- 03.Power Tree
- 04.I2C Map
- 05.Power Domain Map
- 06.RK3399 Power
- 07.RK3399 PMU Controler
- 08.RK3399 DDR Controler
- 09.RK3399 Flash&SDMMC Controler
- 10.RK3399 USB/USIC Controler
- 11.RK3399 SARADC/Key
- 12.RK3399 DVP Interface
- 13.RK3399 Display Interface
- 14.RK3399 GPIO
- 15.RK3399 PCIE
- 16.Power-DC IN
- 17.Power-PMIC RK808-D
- 18.USB OTG/HOST Port
- 19.USB Type-C Port
- 20.RAM-LPDDR3(178P)
- 21.Memory-eMMC
- 22.WIFI/BTMIMO-AP6354
- 23.TF Card
- 24.HDMI Output
- 25.PCie NGFF/M.2
- 26.CONNECTOR

6 LAYERS PCB STACK é g PCB=1.6mm

TOP	Prepreg 1080*1 (75um)	Silkscreen 25um 1oz (35um)
GND1	Prepreg 2116*1 (115um)	Hoz (18um)
POWER	Adjust Core 665um	Hoz (18um)
SIGNAL	Prepreg 2116*1 (115um)	Hoz (18um)
GND2	Prepreg 1080*1 (75um)	Hoz (18um)
BOTTOM		1oz (35um) Silkscreen 25um

Note:

器件参数说明

- 1:如果 Value 为 DP, 请暂时不贴。
- 2:如果 Option 有 DP, 请预留先不贴。

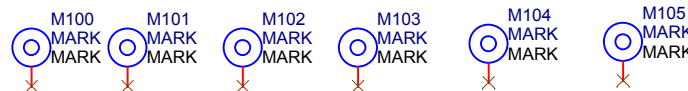
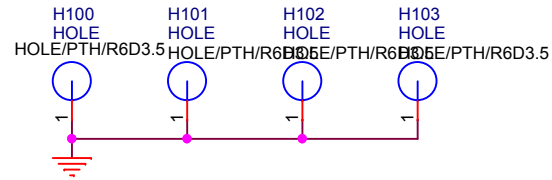

96rocks.com			
Project:	RK3399_ROCK960		
File:	<Page name>		
Date:	Thursday, April 05, 2018	Rev:	V1.0
Designed by:	<designer>	Sheet:	1 of 26

Change List

Version	Date	Author	Change Note	Approved
V1.0	201708	Charlie	First edition	

96rocks.com			
Project:	RK3399_ROCK960		
File:	<Page name>		
Date:	Thursday, April 05, 2018	Rev:	V1.0
Designed by:	<designer>	Sheet:	2 of 26

RK3399 POWER DIAGRAM

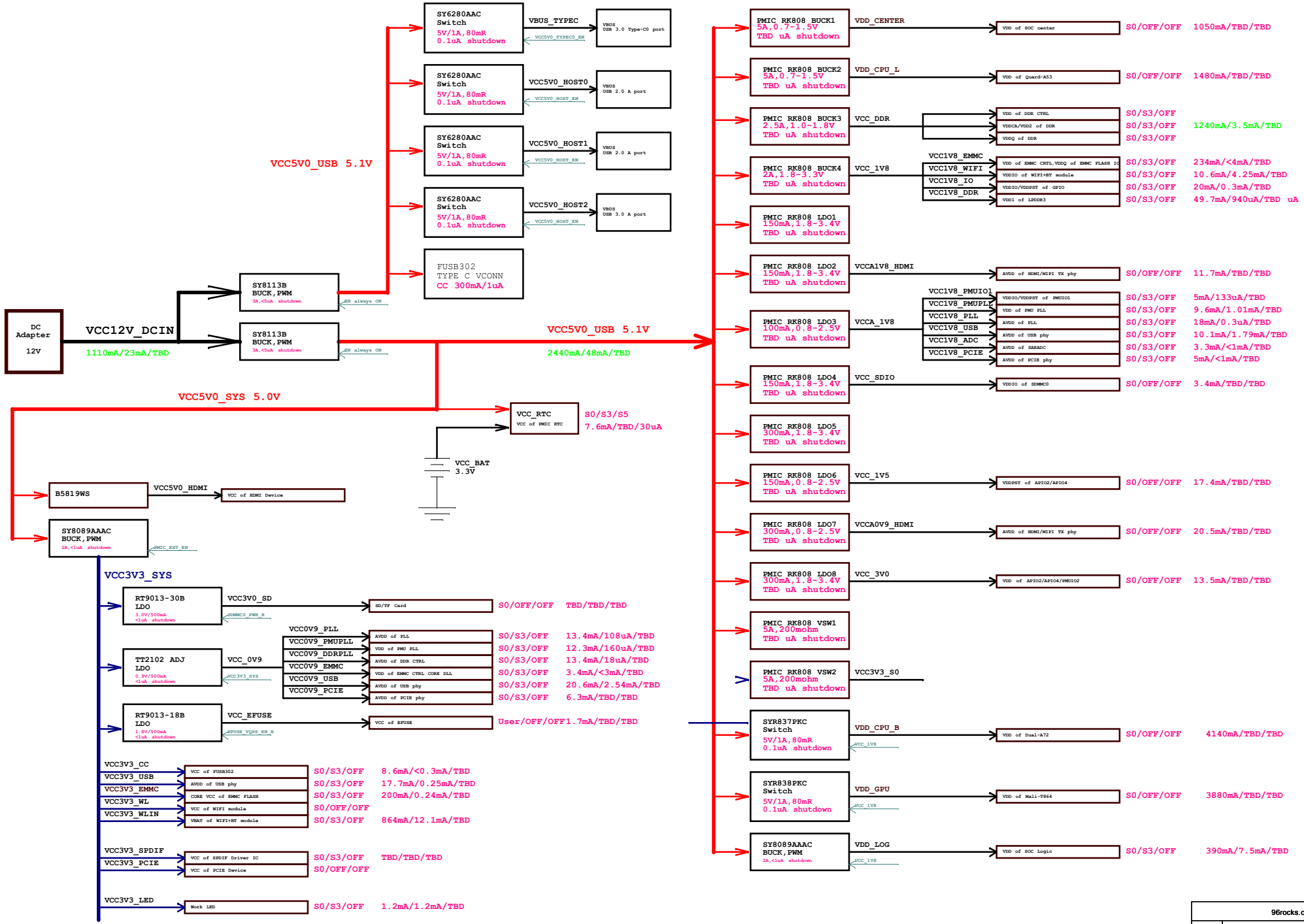

I2C MAP

Port	Pin name	Domain	Bus name	Pull-up voltage	Slave Device	Slave Addr (MS 7Bits)	Note	Slave Bus Capability
I2C0	GPIO1_B7/SPI3_RXD/I2C0_SDA GPIO1_C0/SPI3_TXD/I2C0_SCL	PMUIO2	I2C_SDA_PMIC I2C_SCL_PMIC	VCC_1V8	Rockchip RK808	0x1b	PMIC	100kHz,400KHz
					SYR837PKC	0x40	DC-DC BUCK	100kHz,400KHz,3.4MHz
					SYR838PKC	0x41	DC-DC BUCK	100kHz,400KHz,3.4MHz
I2C1	GPIO4_A1/I2C1_SDA GPIO4_A2/I2C1_SCL	APIO5		VCC_1V8			Low Speed CONNECTOR	
I2C2	GPIO2_A0/VOP_D0/CIF_D0/I2C2_SDA GPIO2_A1/VOP_D1/CIF_D1/I2C2_SCL	APIO2		VCC_1V8			High Speed CONNECTOR	
I2C3	GPIO4_C0/I2C3_SDA/UART2B_RX GPIO4_C1/I2C3_SCL/UART2B_TX	APIO4	I2C_SDA_HDMI I2C_SCL_HDMI	VCC_3V0				
I2C4	GPIO1_B3/I2C4_SDA GPIO1_B4/I2C4_SCL	PMUIO2	I2C_SDA_MEMS I2C_SCL_MEMS	VCC_1V8	Fairchild FUSB302B	0x44,0x46	USB-TypeC Mux	100kHz,400KHz,1MHz
I2C5	GPIO3_B2/MAC_RXER/I2C5_SDA GPIO3_B3/MAC_CLK/I2C5_SCL	APIO1	Other pin function					
I2C6	GPIO2_B1/SPI2_RXD/CIF_HREF/I2C6_SDA GPIO2_B2/SPI2_TXD/CIF_CLKIN/I2C6_SCL	APIO2		VCC_1V8			Low Speed CONNECTOR	
I2C7	GPIO2_A7/VOP_D7/CIF_D7/I2C7_SDA GPIO2_B0/VOP_CLK/CIF_VSYNC/I2C7_SCL	APIO2		VCC_1V8			High Speed CONNECTOR	

96rocks.com			
Project:	RK3399_ROCK960		
File:	<Page name>		
Date:	Thursday, April 05, 2018	Rev:	V1.0
Designed by:	<designer>	Sheet:	4 of 26

Power Domain Map

Part Port	Domain	Pin name in datasheet	I/O type	Power supply	Power source
Part C	PMUIO1	pmuiol_gpio0ab	1.8V only	VCCA_1V8	RK808-D VLDO3
Part E	PMUIO2	pmu1830_gpio1abcd	1.8V (Default) 3.0V	VCC_1V8	RK808-D Buck4
Part I	APIO1	gmac_gpio3abc	3.3V only	VCC_1V8 VCC3V3_SYS	RK808-D Buck4
Part L	APIO2	bt656_gpio2ab	1.8V (Default) 3.0V	VCC_1V8	RK808-D VLDO3
Part G	APIO3	wifi/bt_gpio2cd	1.8V only	VCC_1V8	RK808-D Buck4
Part K	APIO4	gpio1830_gpio4cd	1.8V 3.0V (Default)	VCC_1V5 VCC_3V0	RK808-D VLDO6 RK808-D VLDO8
Part J	APIO5	audio_gpio3d_gpio4a	1.8V (Default) 3.0V	VCC_1V8	RK808-D Buck4
Part F	SDMMC0	sdmmc_gpio4b	1.8V 3.0V (Default)	VCC_SDIO	RK808-D VLDO4

96rocks.com			
Project:	RK3399_ROCK960		
File:	<Page name>		
Date:	Thursday, April 05, 2018	Rev:	V1.0
Designed by:	<designer>	Sheet:	5 of 26

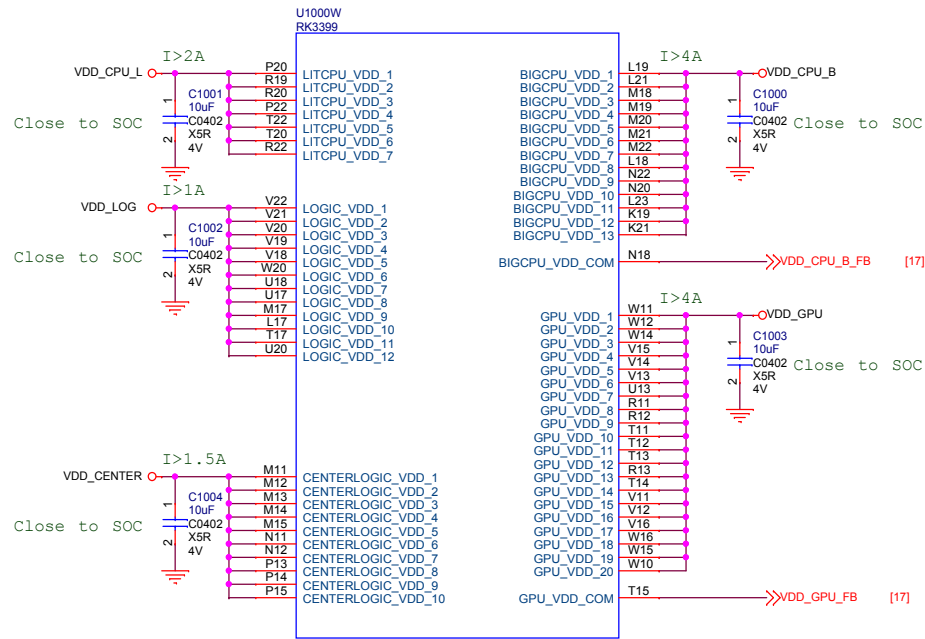

Note: Power filter CAP please place back of SOC or close to SOC

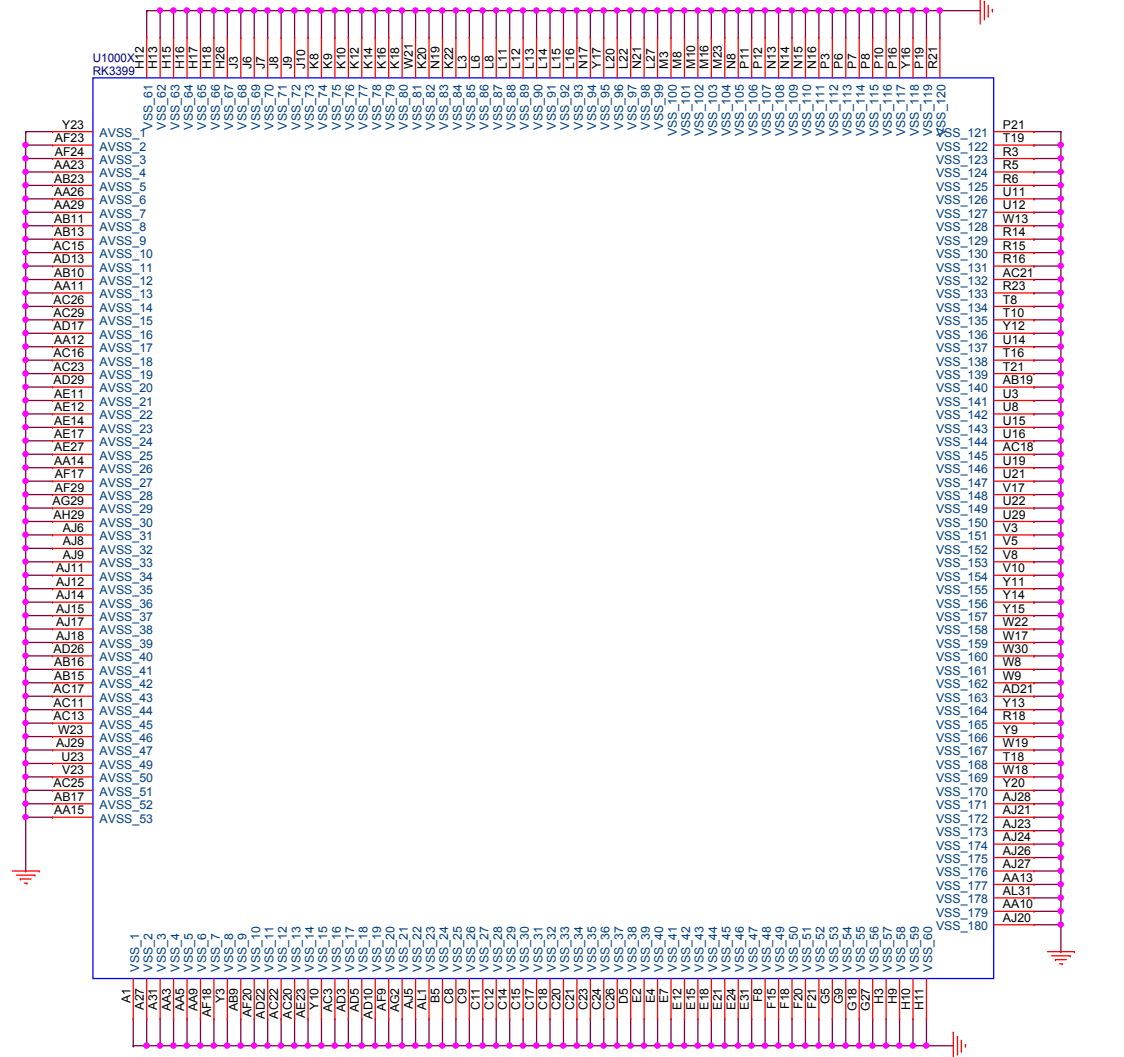
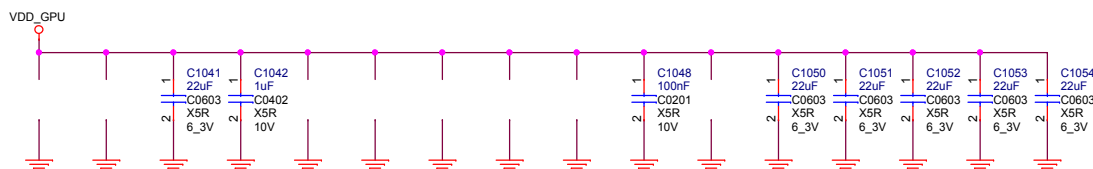
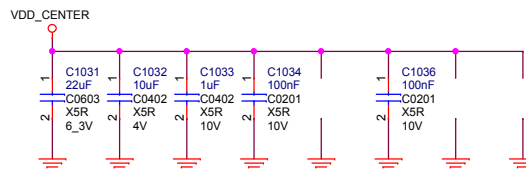
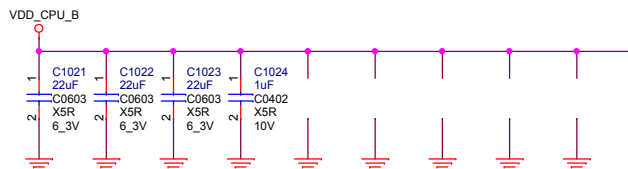
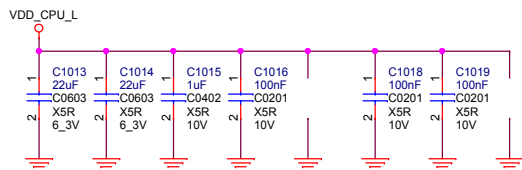
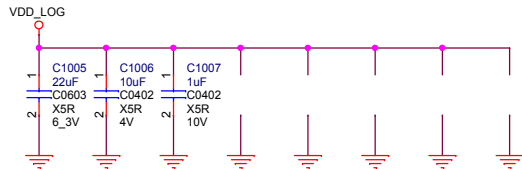

96rocks.com			
Project:	RK3399_ROCK960		
File:	<Page name>		
Date:	Thursday, April 05, 2018	Rev:	V1.0
Designed by:	<designer>	Sheet:	6 of 26

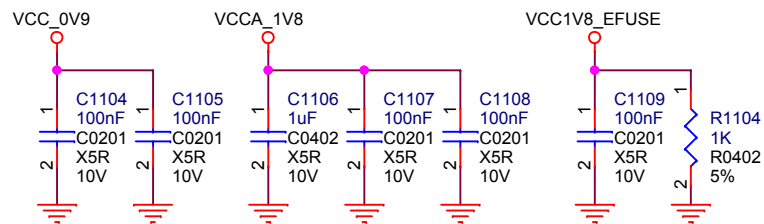
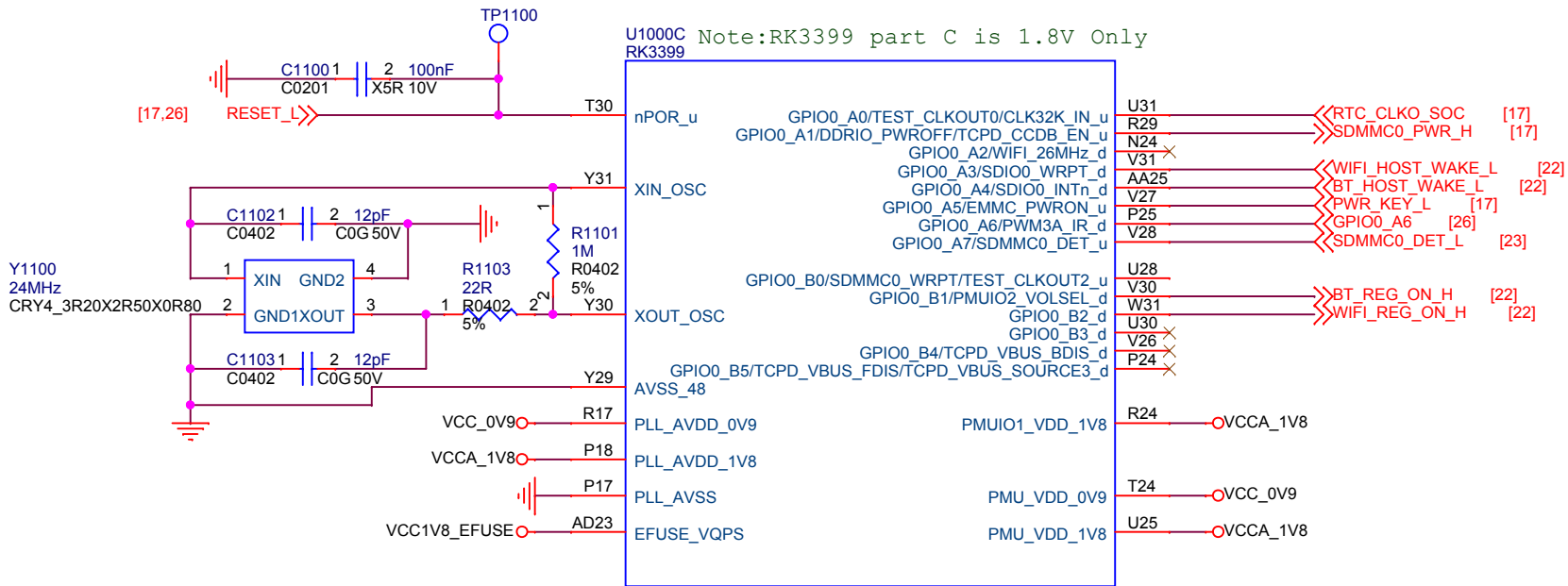

96rocks.com			
Project:	RK3399_ROCK960		
File:	<Page name>		
Date:	Thursday, April 05, 2018	Rev:	V1.0
Designed by:	<designer>	Sheet:	7 of 26

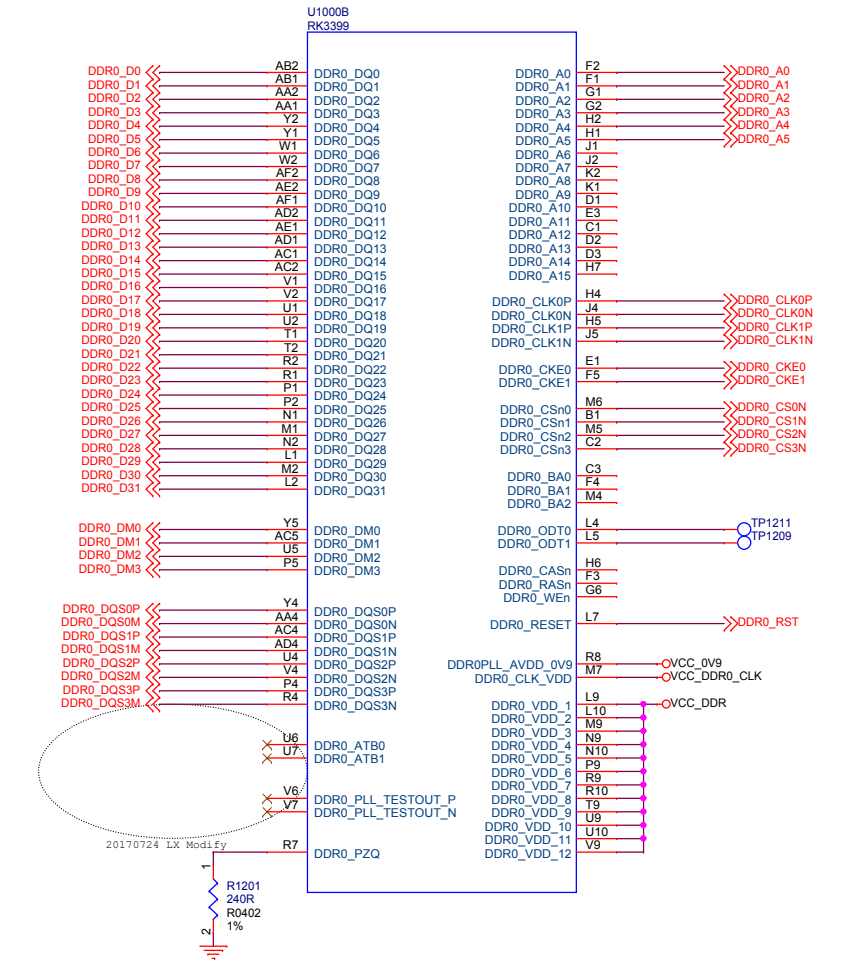
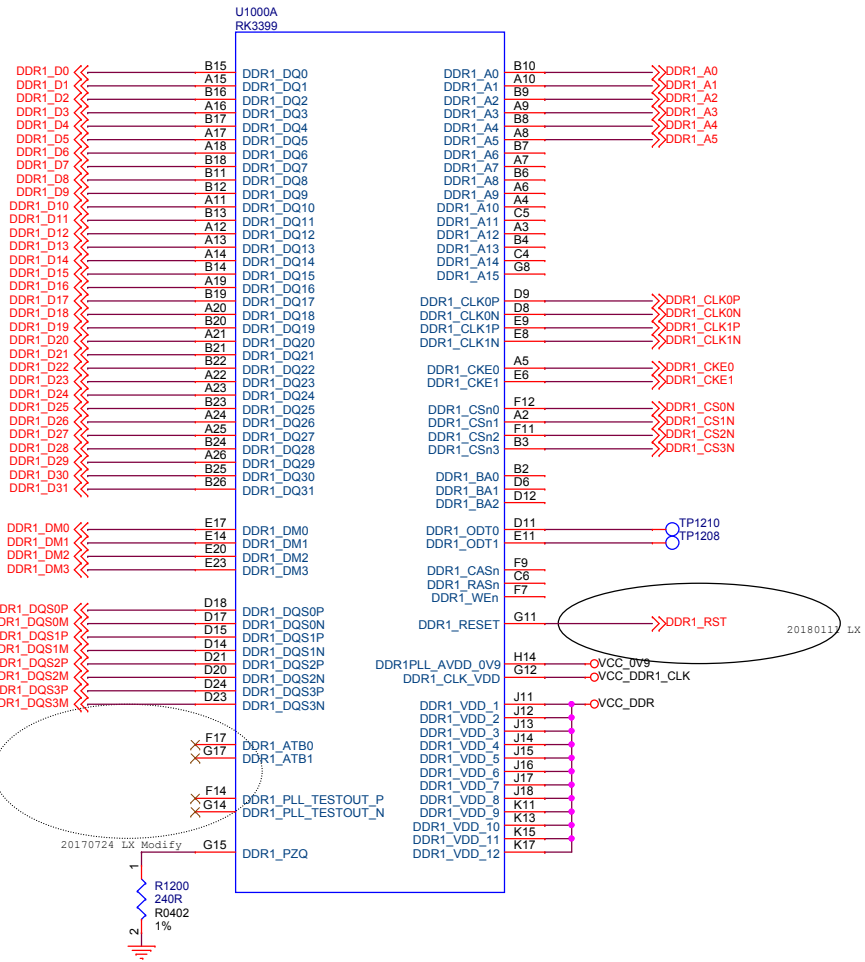

DDR FILTER Note:R1202 cannot be deleted

DDR FILTER Note:R1203 cannot be deleted

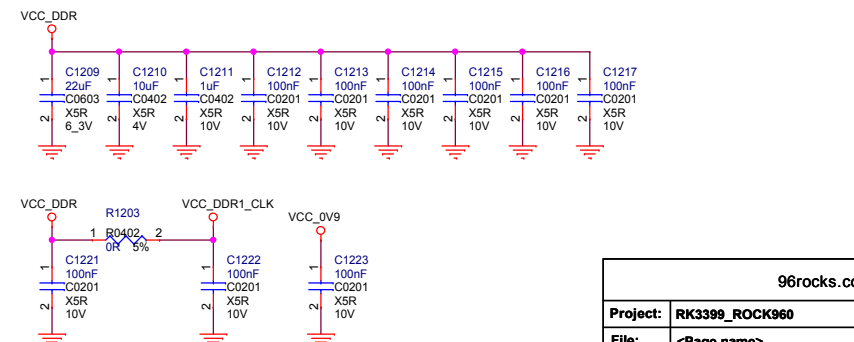
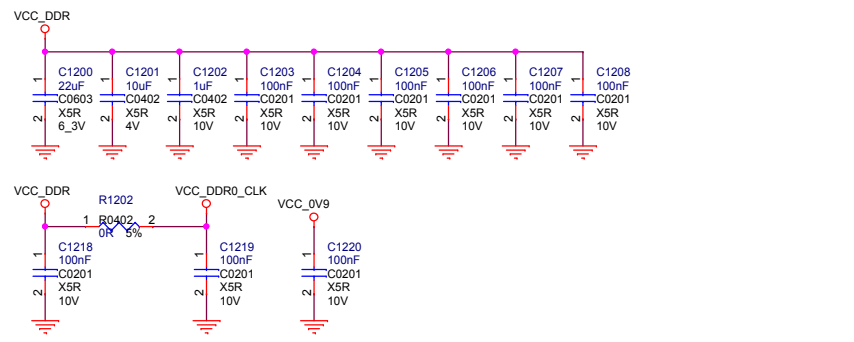

96rocks.com			
Project:	RK3399_ROCK960		
File:	<Page name>		
Date:	Thursday, April 05, 2018	Rev:	V1.0
Designed by:	<designer>	Sheet:	8 of 26

U1000H
RK3399

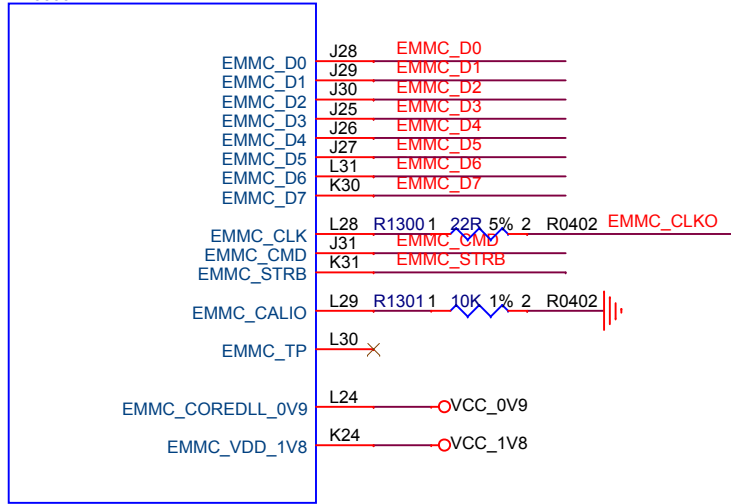

EMMC design rule:

1. Data[0:7]、cmd strobe 为一组并行走线并包地，组内等长要求为 +/-100 mil；
2. Clk 需要单独走线并包地处理，与 data 间的延时小于 2ps；
3. Max trace length < 3.93 inches；
4. Trace impedance 50ohm +/-10%；
5. 与其他信号间距遵循 3W 原则；
6. R1300 靠 SOC 放置；

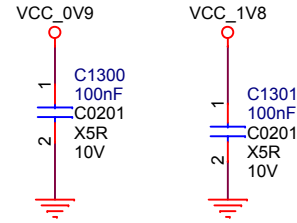
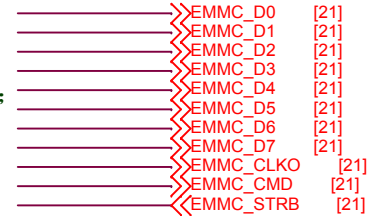

U1000F
RK3399

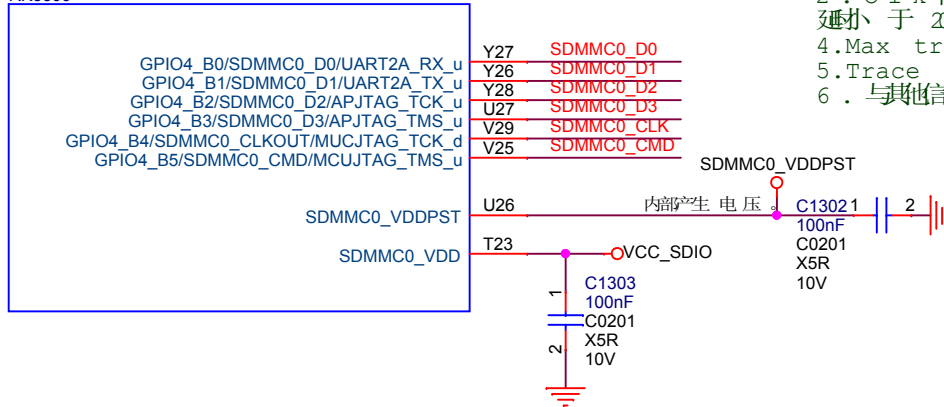

SDMMC design rule:

1. Data[0:3]、cmd 为一组，并行走线并包地，组内等长要求为 +/-100 mil；
2. Clk 需要单独走线并包地处理，与 data 间的延时小于 2ps；
3. Max trace length < 3.93 inches；
4. Trace impedance 50ohm +/-10%；
5. 与其他信号间距遵循 3W 原则；



96rocks.com			
Project:	RK3399_ROCK960		
File:	<Page name>		
Date:	Thursday, April 05, 2018	Rev:	V1.0
Designed by:	<designer>	Sheet:	9 of 26

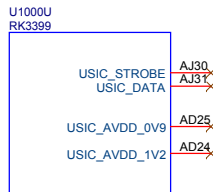

USB2.0

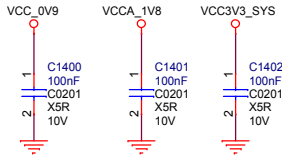
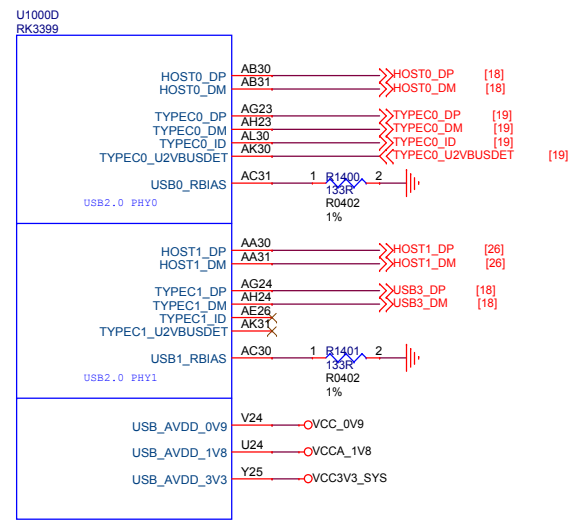

USB2.0 design rule:
 1. Max intra-pair skew < 4 ps;
 2. Max trace length < 6 inchs;
 3. Max allowed via < 6;
 4. Trace impedance 90ohm+/-10%;
 5. 与其他信号间距遵循 3原则;

USB3.0

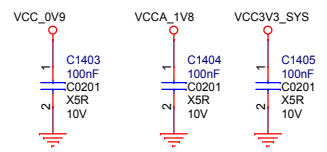
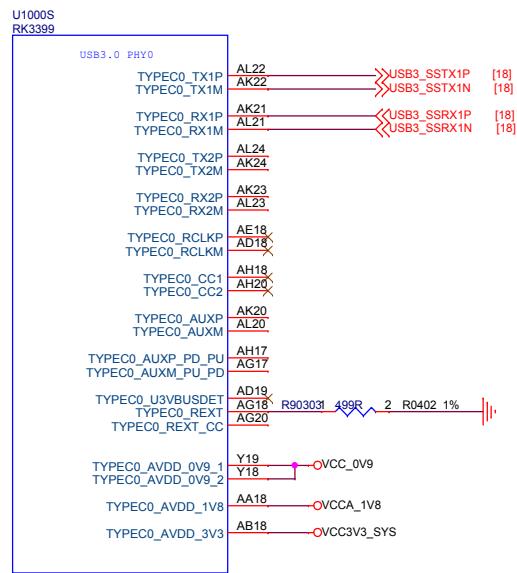

USB3.0 design rule:
 1. Max intra-pair skew < 4 ps;
 2. Max length skew between TX and RX < 1.6 ns;
 3. Max trace length < 6 inchs;
 4. Max allowed via < 4;
 5. Trace impedance 90ohm+/-10%;
 6. 与其他信号间距遵循 3原则;

DP design rule:
 1. Max intra-pair skew < 4 ps;
 2. Max trace length < 6 inchs;
 3. Max allowed via < 4;
 4. Trace impedance 90ohm+/-10%;
 5. 与其他信号间距遵循 3原则;

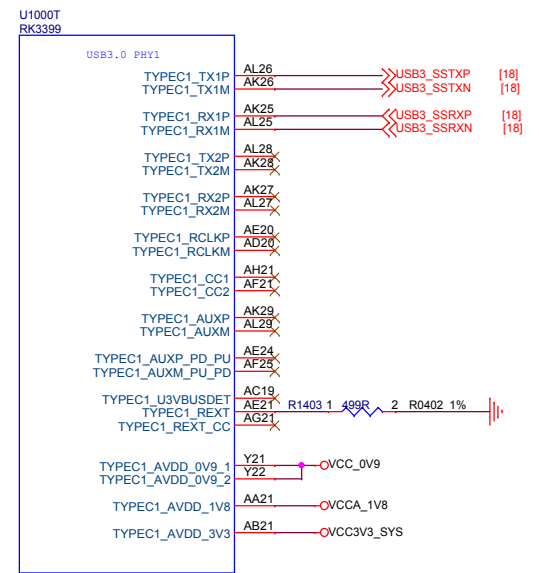

96rocks.com			
Project:	RK3399_ROCK960		
File:	<Page name>		
Date:	Thursday, April 05, 2018	Rev:	V1.0
Designed by:	<designer>	Sheet:	10 of 26

U1000V
RK3399

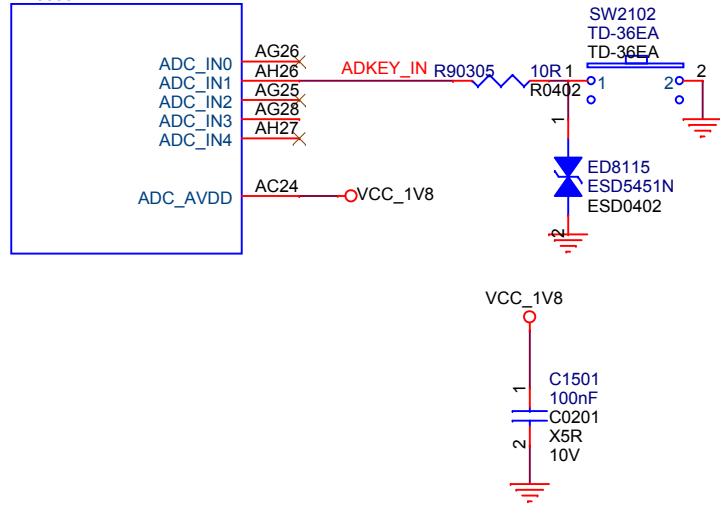

KEY BAORD

Note:
系统时, 如果 ADKEY_IN 电平为 0V,
则 RK3399 进入 Recover 模式;
量产时 R1503, SW1500, ED1500 不用贴片



96rocks.com

96rocks.com			
Project:	RK3399_ROCK960		
File:	<Page name>		
Date:	Thursday, April 05, 2018	Rev:	V1.0
Designed by:	<designer>	Sheet:	11 of 26

U1000L
RK3399

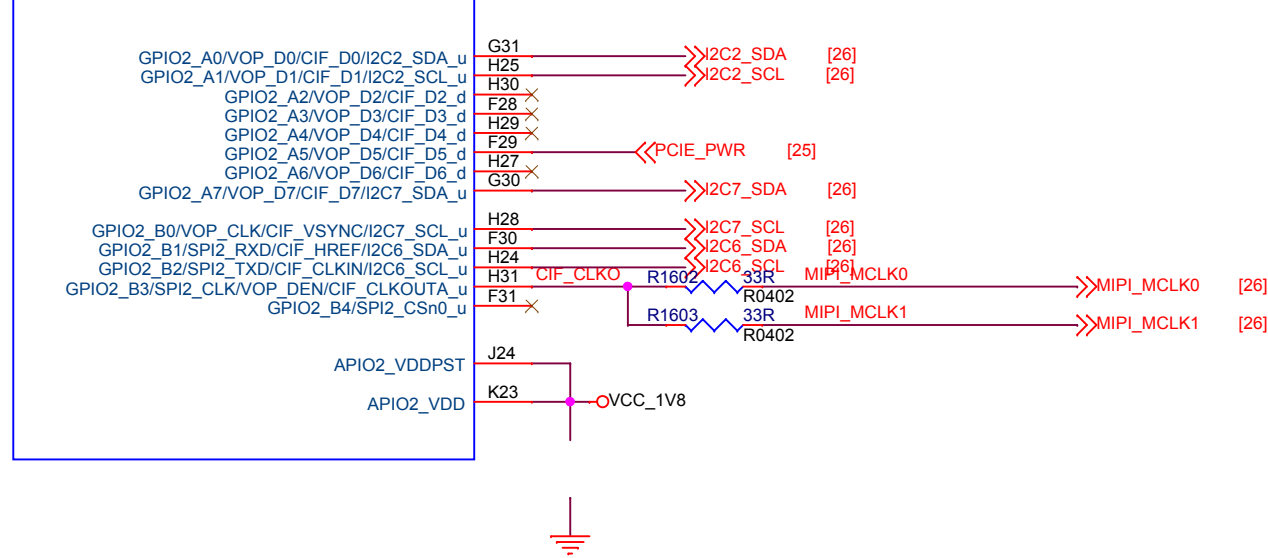

U1000R
RK3399

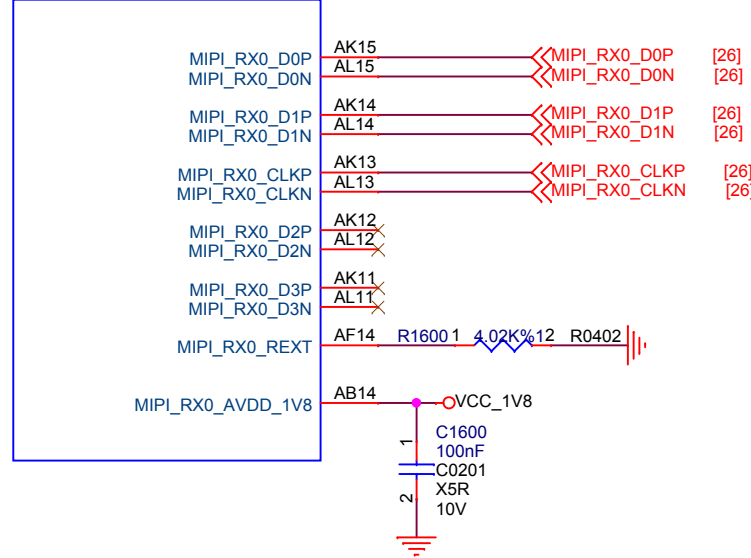

U1000P
RK3399

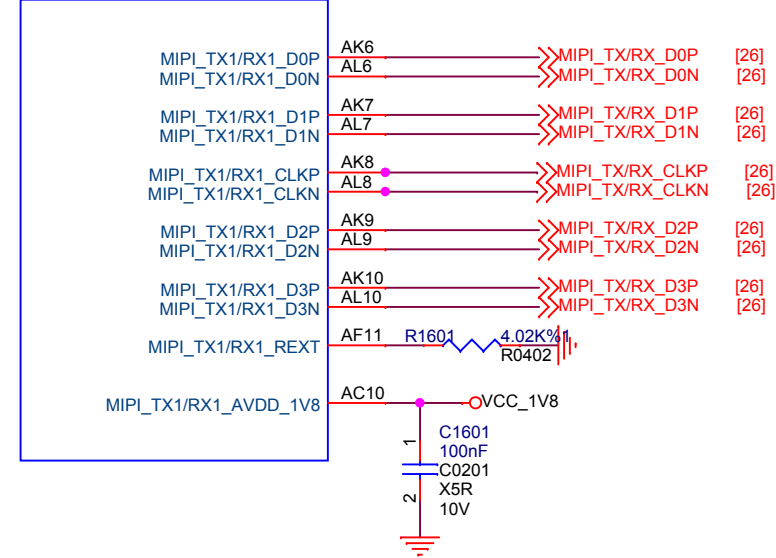

Dual
MIPI
Right

96rocks.com			
Project:	RK3399_ROCK960		
File:	<Page name>		
Date:	Thursday, April 05, 2018	Rev:	V1.0
Designed by:	<designer>	Sheet:	12 of 26

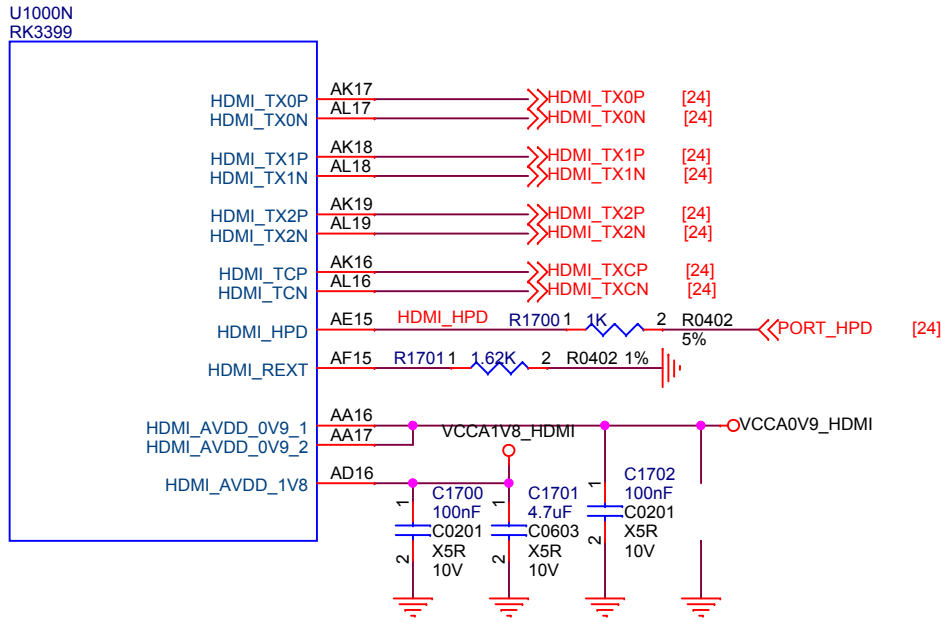

HDMI design rule:

1. Max intra-pair skew < 4 ps;
2. Max length skew between clk and data < 80 ps;
3. Max trace length < 9.8 inches;
4. Max allowed via < 4;
5. Trace impedance 100ohm+/-10%;
6. 与其他信号间距遵循3原则;

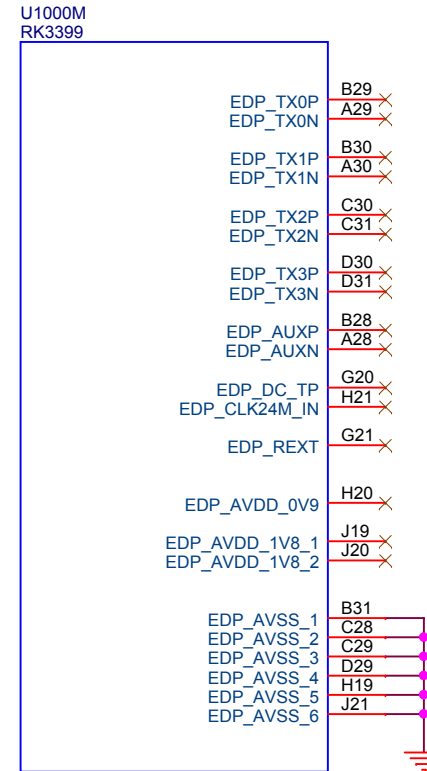

eDP design rule:

1. Max intra-pair skew < 4 ps;
2. Max trace length < 6 inches;
3. Max allowed via < 4;
4. Trace impedance 90ohm+/-10%;
5. 与其他信号间距遵循3原则;

MIPI design rule:

1. Max intra-pair skew < 4 ps;
2. Max length skew between clk and data < 7ps;
3. Max trace length < 7.2 inches;
4. Max allowed via < 4;
5. Trace impedance 100ohm+/-10%;
6. 与其他信号间距遵循3原则;

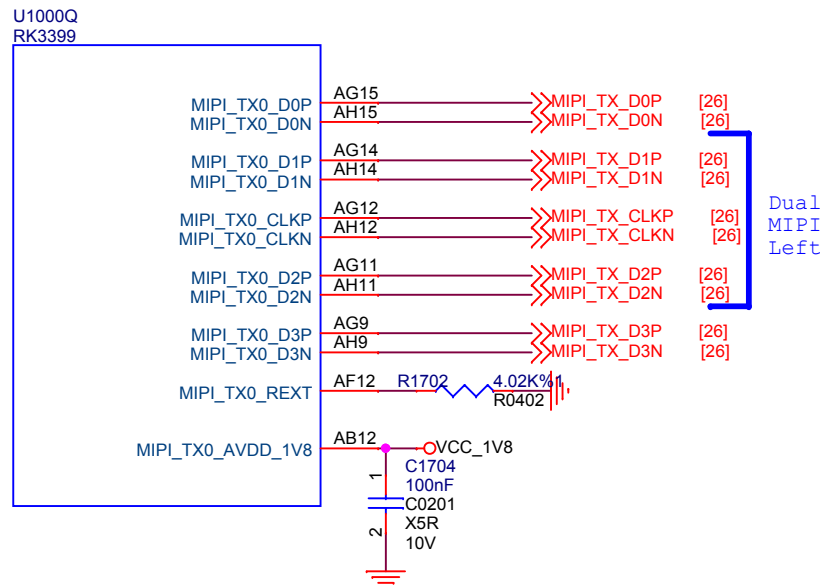

96rocks.com			
Project:	RK3399_ROCK960		
File:	<Page name>		
Date:	Thursday, April 05, 2018	Rev:	V1.0
Designed by:	<designer>	Sheet:	13 of 26

U1000I Note:RK3399 part I is 3.3V only
RK3399

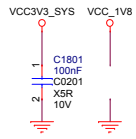
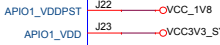
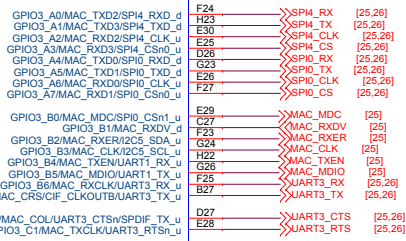

U1000G Note:RK3399 part G is 1.8V only
RK3399

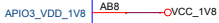
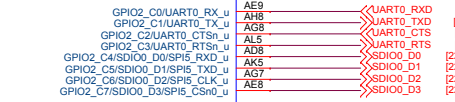

SDIO design rule:
1. Data[0:3].cm 为一组，并行以最佳地，组内等长要求为 +/-100 mil；
2. CLK 需单独包地处理，与 data 的线长小于 2ps；
3. Max trace length < 3.93 inches；
4. Trace impedance 50ohm +/-10%；
5. 与轴间距遵循 3原则；



U1000J Note:RK3399 part J is 1.8V/3.0V mode
RK3399

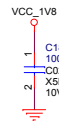
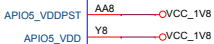

U1000E Note:RK3399 part E is 1.8V/3.0V mode
RK3399

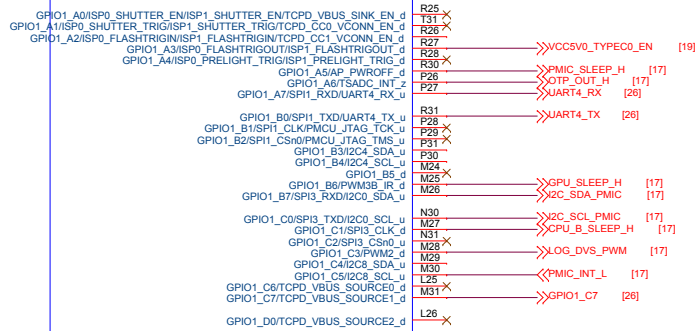

1.8V Only	VDDPST=VDDIO=1.8V
3.3V Only	VDDPST=1.8V, VDDIO=3.3V
other	3.0V mode: VDDPST=1.5V, VDDIO=3.0V 1.8V mode: VDDPST=1.8V, VDDIO=1.8V

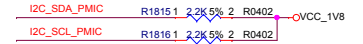
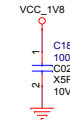

U1000K Note:RK3399 part J is 1.8V/3.0V mode
RK3399

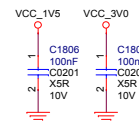
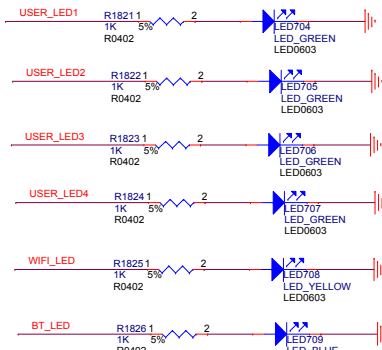
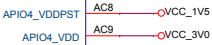
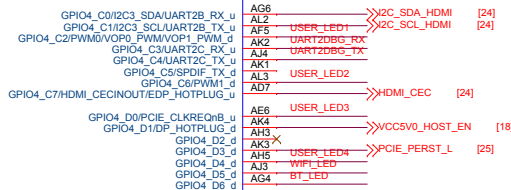

U10000
RK3399

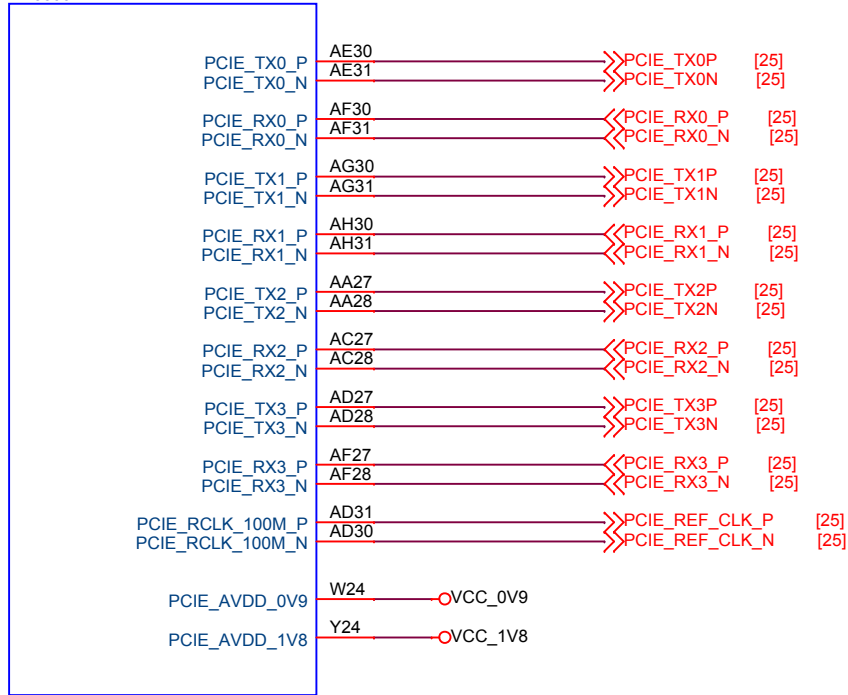

PCIE design rule:

1. Max intra-pair skew < 4ps;
2. Max inter-pair skew < 1.6 ns;
3. Max trace length < 14 inches;
4. Max allowed via < 4;
5. Trace impedance 100ohm+/-10%;
6. 与其他信号间距遵循3原则;

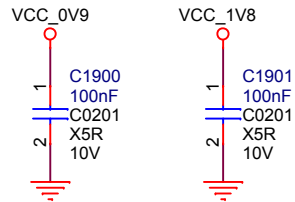

96rocks.com			
Project:	RK3399_ROCK960		
File:	<Page name>		
Date:	Thursday, April 05, 2018	Rev:	V1.0
Designed by:	<designer>	Sheet:	15 of 26

DC IN&SYSTEM Power

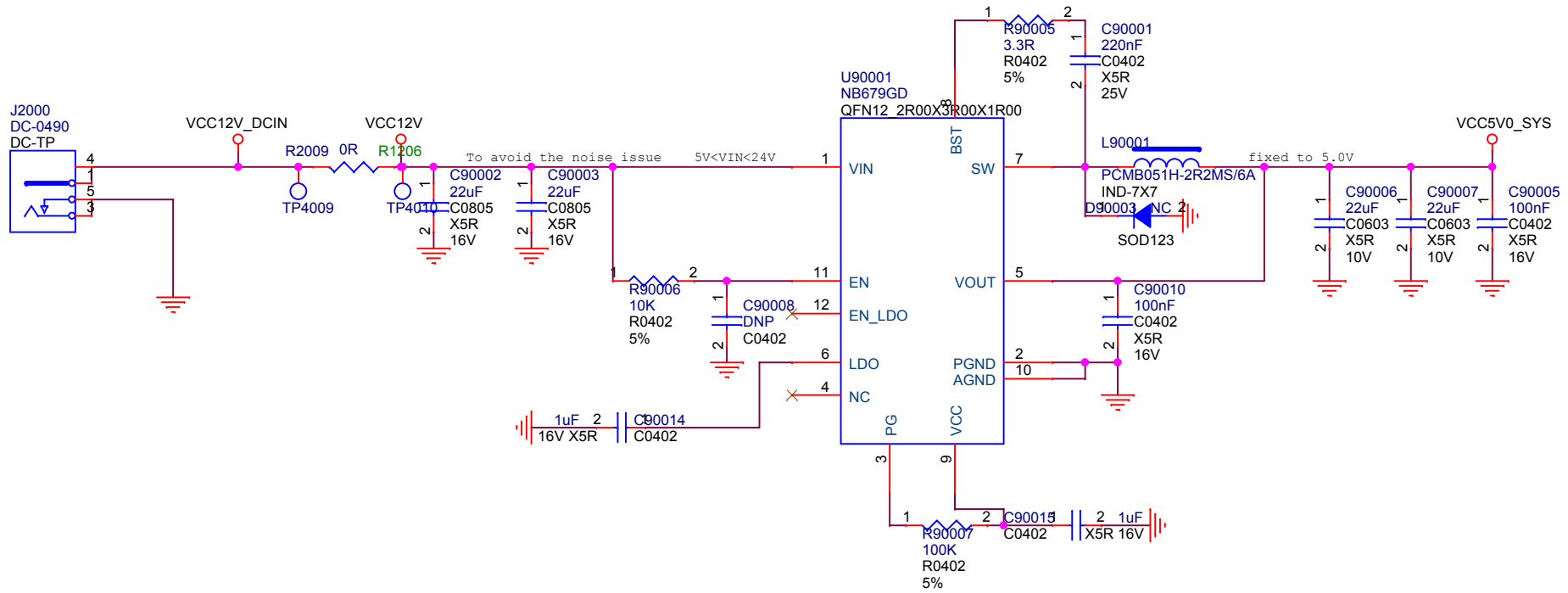

96rocks.com			
Project:	RK3399_ROCK960		
File:	<Page name>		
Date:	Thursday, April 05, 2018	Rev:	V1.0
Designed by:	<designer>	Sheet:	16 of 26

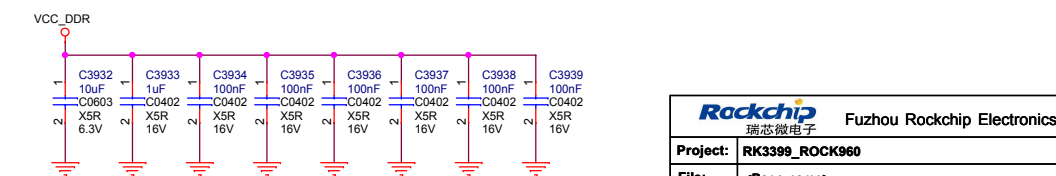
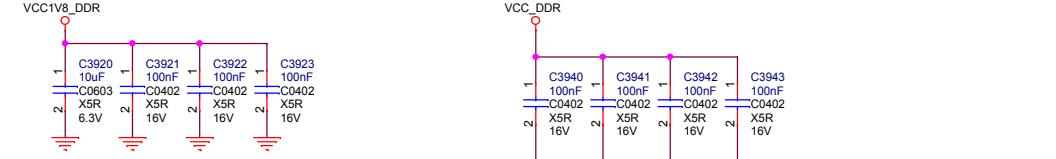
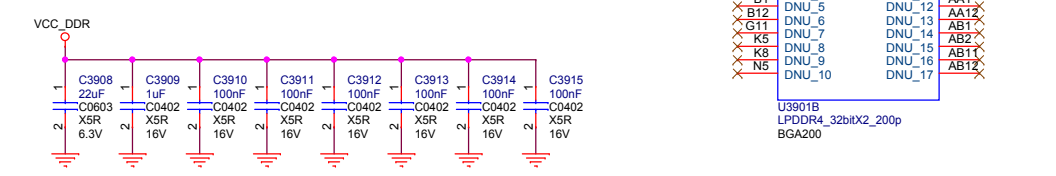
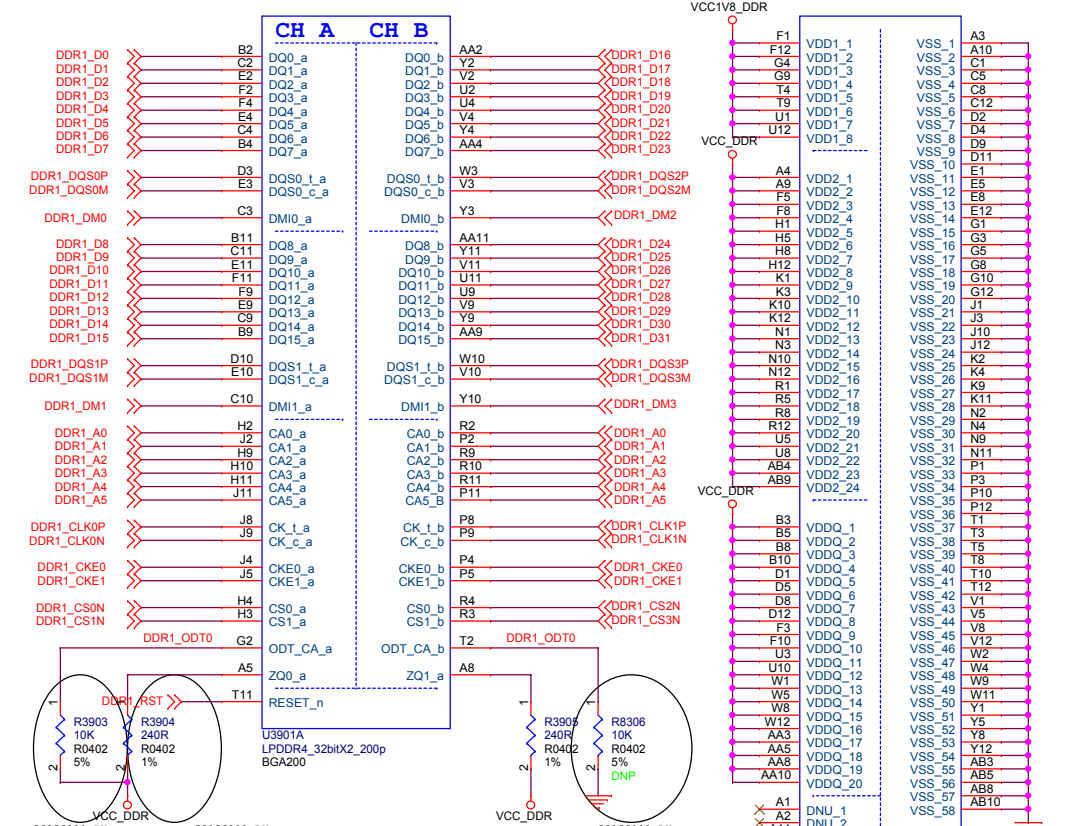
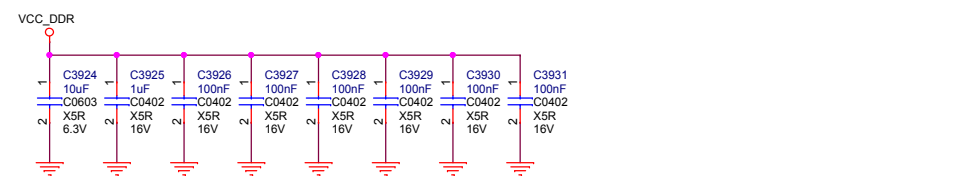
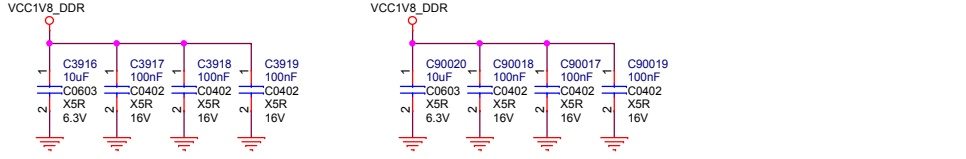
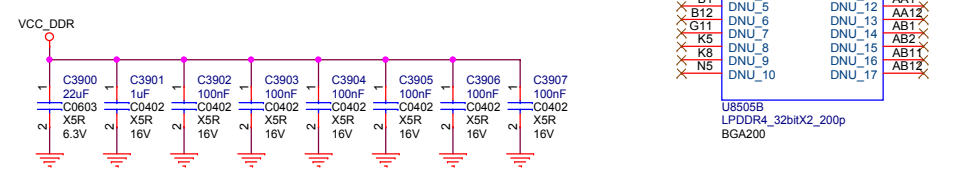
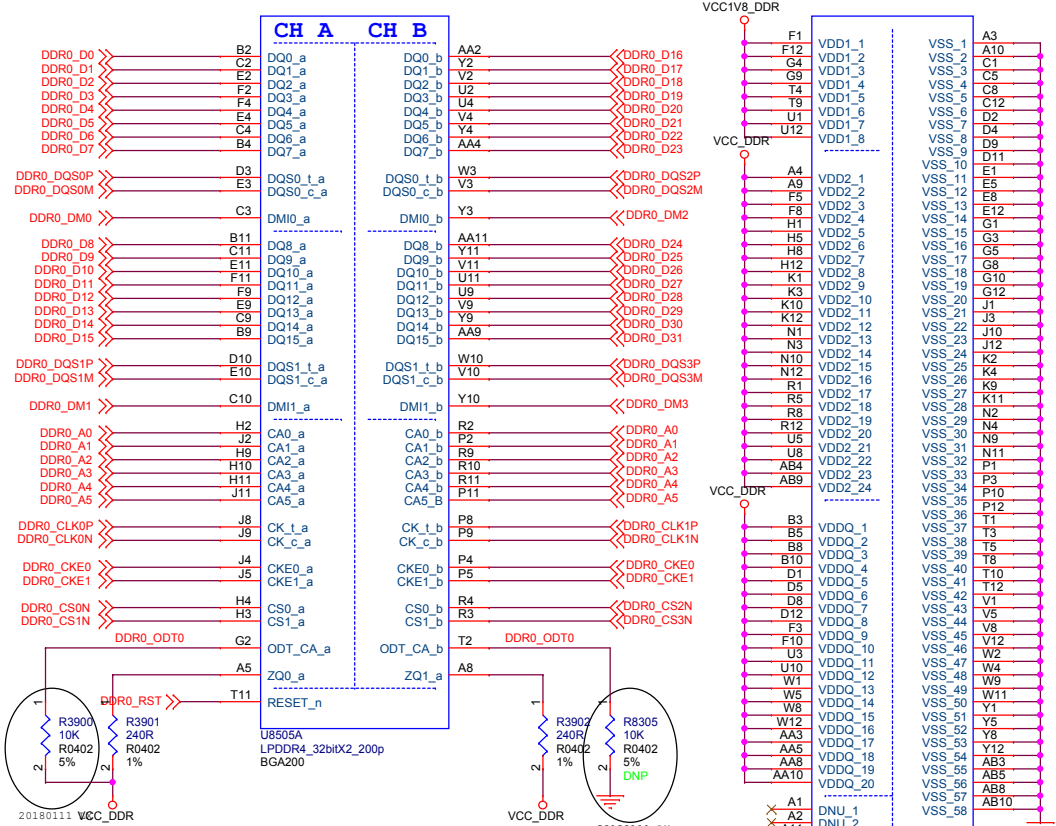

USB2.0 port

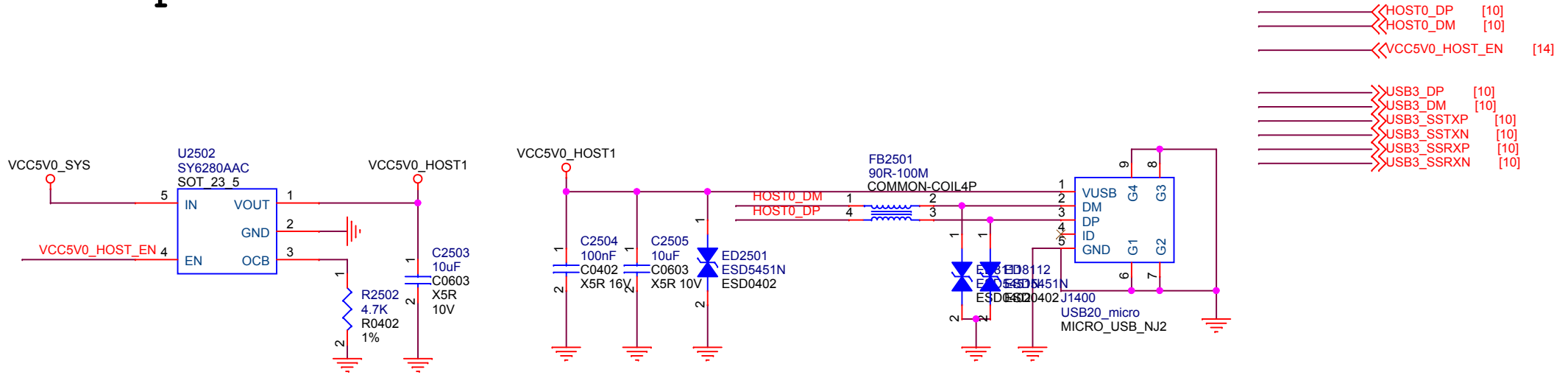

USB3.0 port

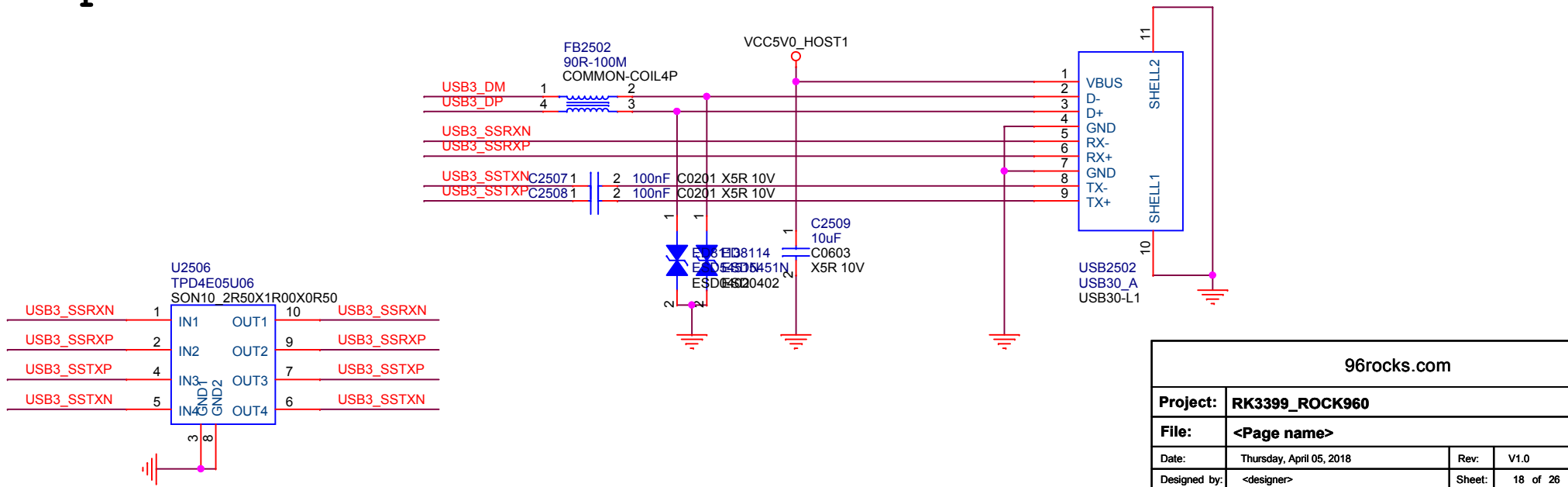

96rocks.com			
Project:	RK3399_ROCK960		
File:	<Page name>		
Date:	Thursday, April 05, 2018	Rev:	V1.0
Designed by:	<designer>	Sheet:	18 of 26

USB3.0 OTG port

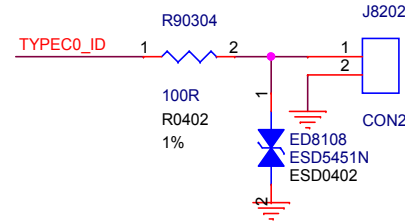
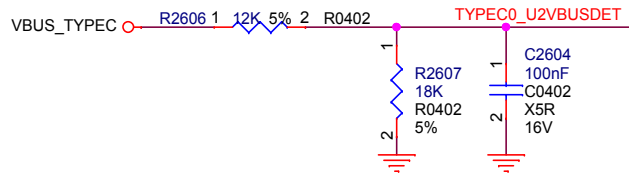

- >>TYPEC0_ID [10]
- >>TYPEC0_DP [10]
- >>TYPEC0_DM [10]
- >>VCC5V0_TYPEC0_EN [14]
- >>TYPEC0_U2VBUSDET [10]
- >>USB3_SSTX1P [18]
- >>USB3_SSTX1N [18]
- >>USB3_SSRX1P [18]
- >>USB3_SSRX1N [18]

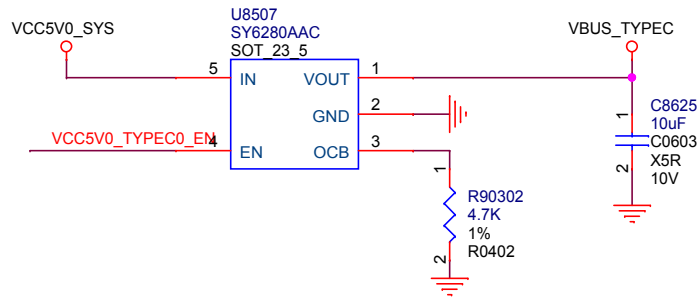
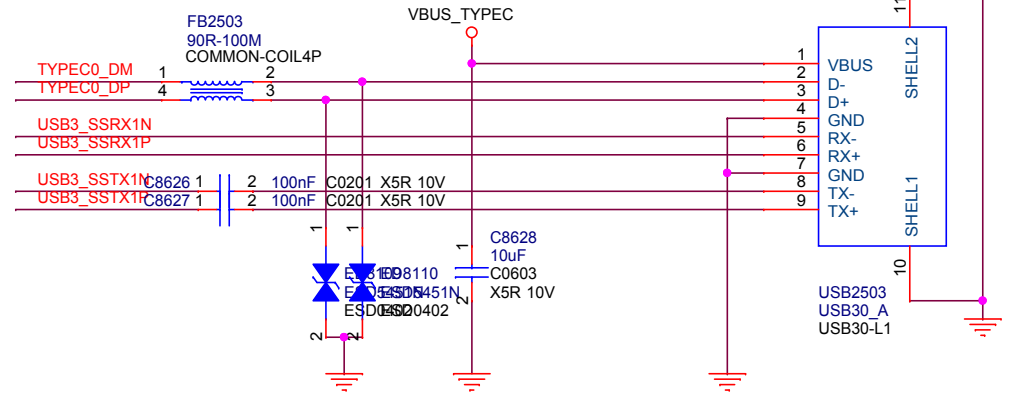
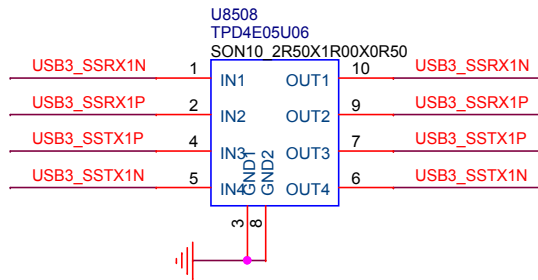

96rocks.com			
Project:	RK3399_ROCK960		
File:	<Page name>		
Date:	Thursday, April 05, 2018	Rev:	V1.0
Designed by:	<designer>	Sheet:	19 of 26

eMMC FLASH

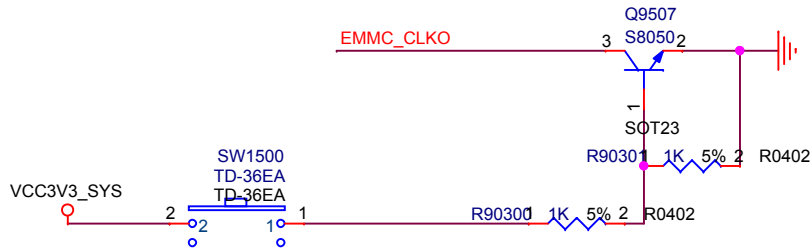
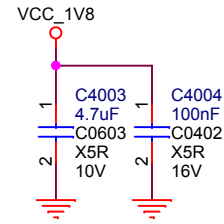
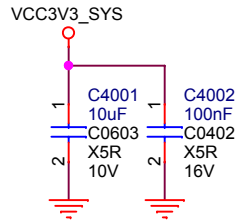
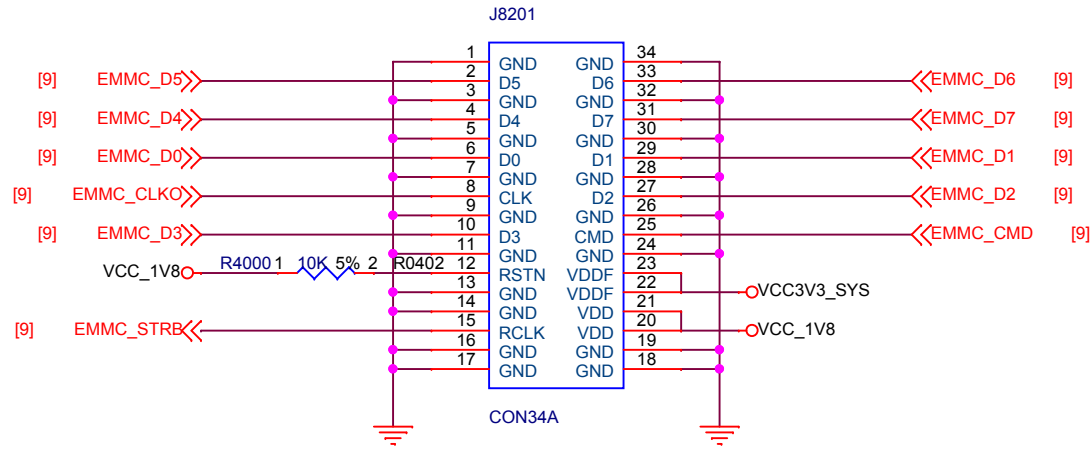

96rocks.com			
Project:	RK3399_ROCK960		
File:	<Page name>		
Date:	Thursday, April 05, 2018	Rev:	V1.0
Designed by:	<designer>	Sheet:	21 of 26

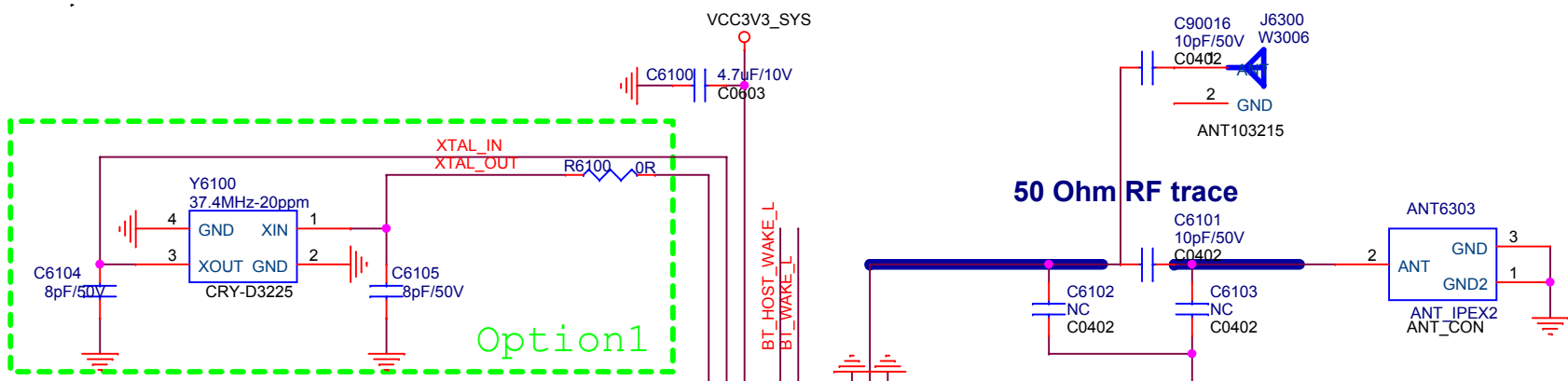

- SDIO0_D0 [14]
- SDIO0_D1 [14]
- SDIO0_D2 [14]
- SDIO0_D3 [14]
- SDIO0_CMD [14]
- SDIO0_CLK [14]
- UART0_RTS [14]
- UART0_TXD [14]
- UART0_RXD [14]
- UART0_CTS [14]
- BT_HOST_WAKE_L [7]
- BT_WAKE_L [14]
- BT_REG_ON_H [7]
- WIFI_REG_ON_H [7]
- WIFI_HOST_WAKE_L [7]
- RTC_CLKO_WIFI [17,22]

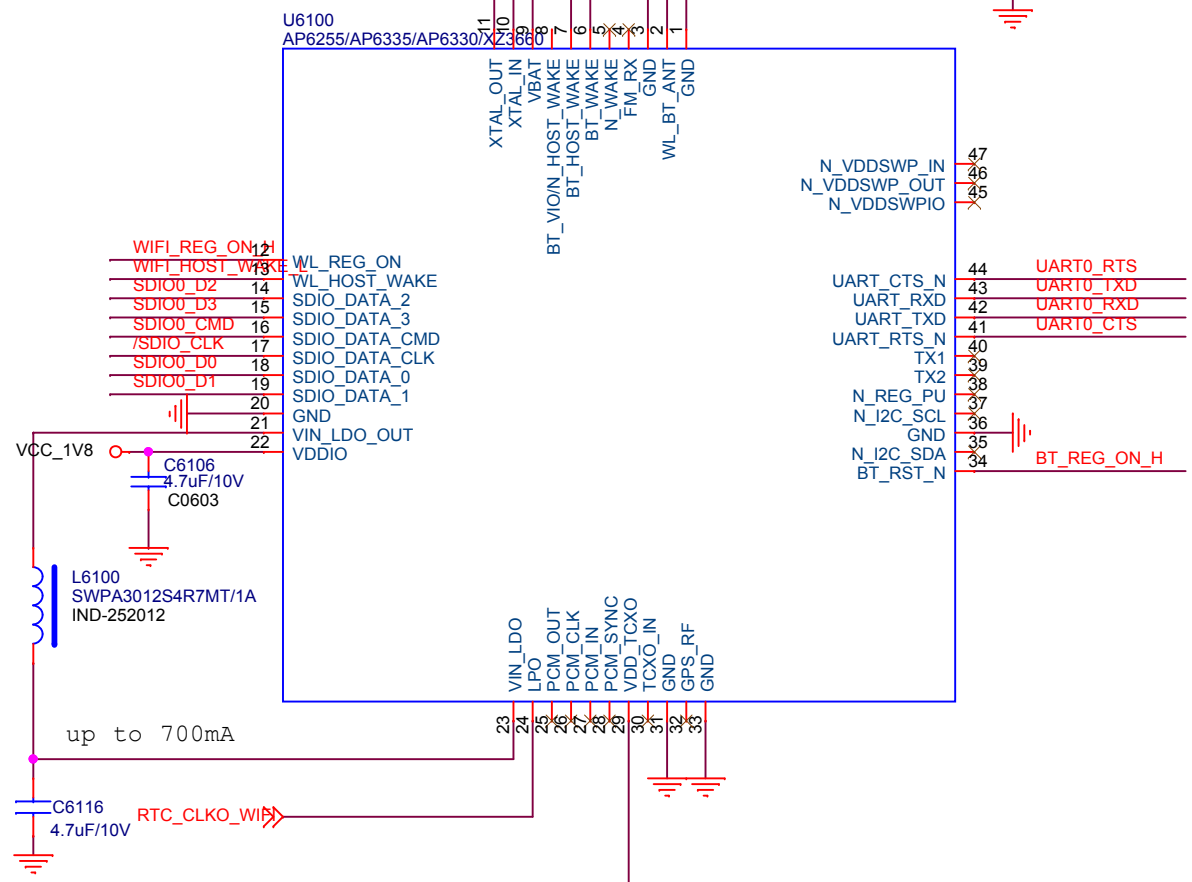

- WIFI_REG_ON [12]
- WIFI_HOST_WAKE [13]
- SDIO0_D2 [14]
- SDIO0_D3 [15]
- SDIO0_CMD [16]
- /SDIO_CLK [17]
- SDIO0_D0 [18]
- SDIO0_D1 [19]
- SDIO0_D2 [14]
- SDIO0_D3 [15]
- SDIO0_CMD [16]
- /SDIO_CLK [17]
- SDIO0_D0 [18]
- SDIO0_D1 [19]
- SDIO0_D2 [14]
- SDIO0_D3 [15]
- SDIO0_CMD [16]
- /SDIO_CLK [17]
- SDIO0_D0 [18]
- SDIO0_D1 [19]

50 Ohm RF trace

/SDIO_CLK R6306 1 33R 5% 2 R0402 **SDIO0_CLK**



96rocks.com			
Project:	RK3399_ROCK960		
File:	<Page name>		
Date:	Thursday, April 05, 2018	Rev:	V1.0
Designed by:	<designer>	Sheet:	22 of 26

TF CARD

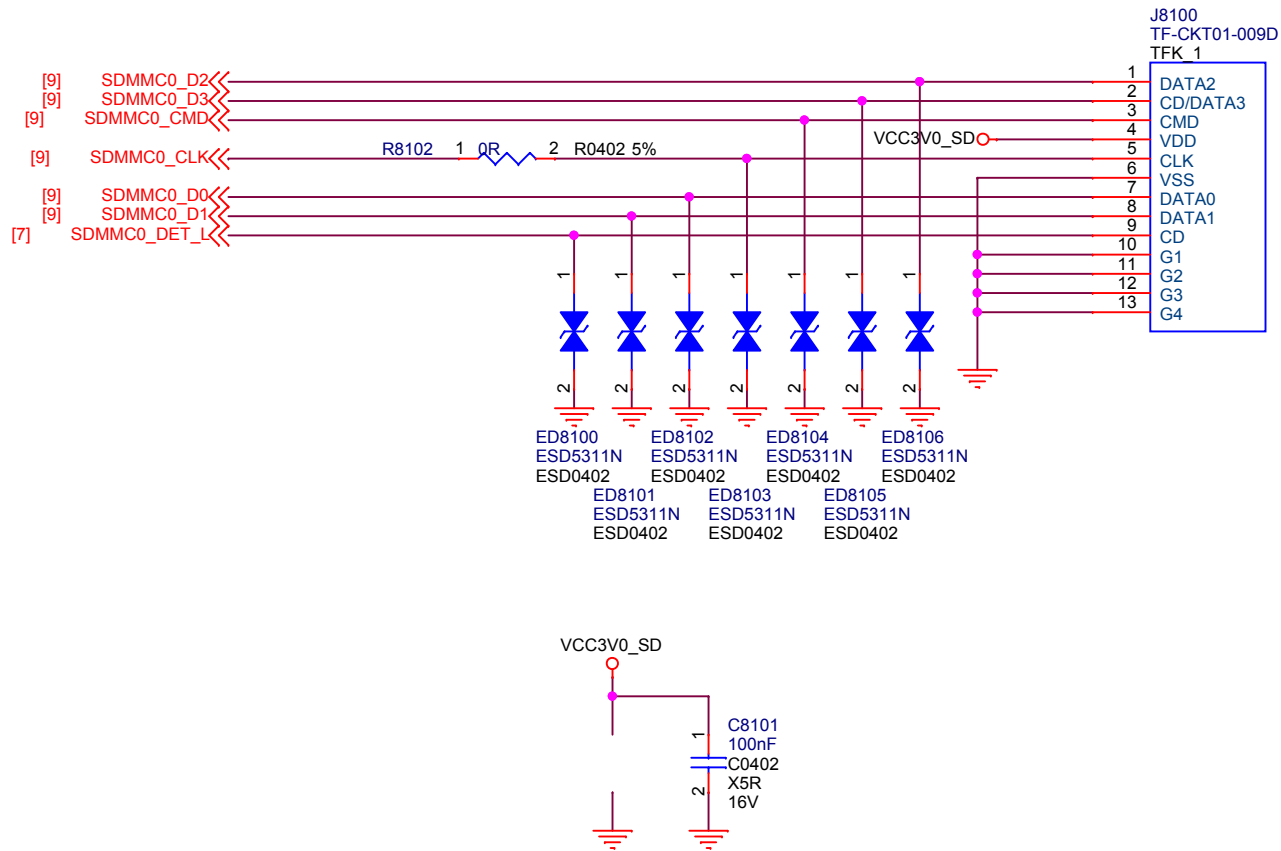

96rocks.com			
Project:	RK3399_ROCK960		
File:	<Page name>		
Date:	Thursday, April 05, 2018	Rev:	V1.0
Designed by:	<designer>	Sheet:	23 of 26

HDMI Output

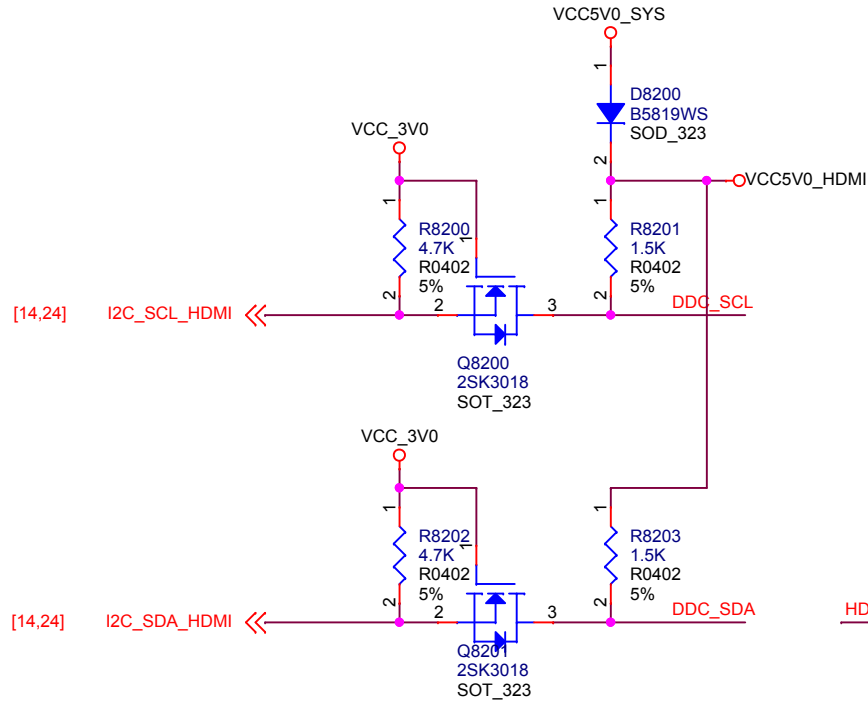
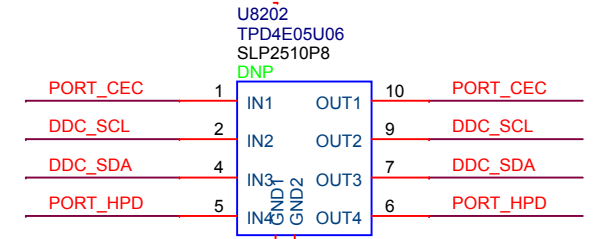
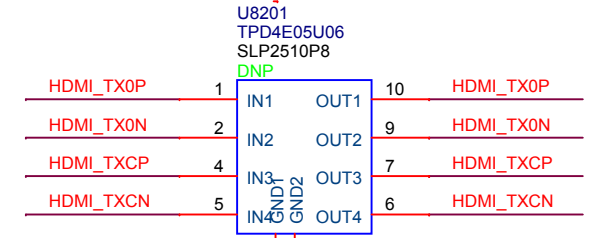
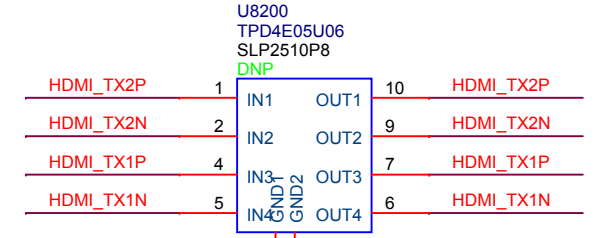
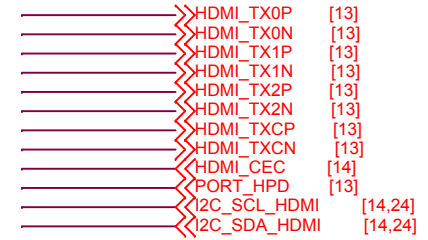
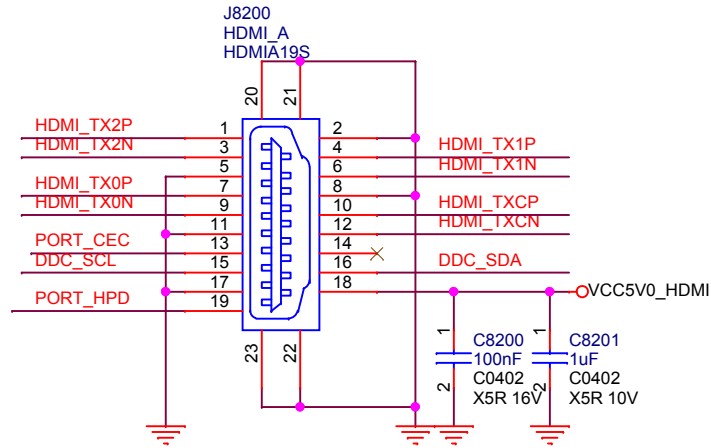

96rocks.com			
Project:	RK3399_ROCK960		
File:	<Page name>		
Date:	Thursday, April 05, 2018	Rev:	V1.0
Designed by:	<designer>	Sheet:	24 of 26

PCIe NGFF/M.2

U8500
M.2 NGFF MKEY SOCKET

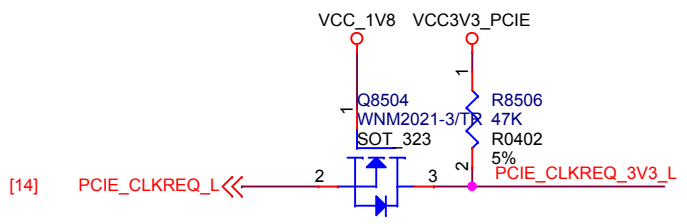
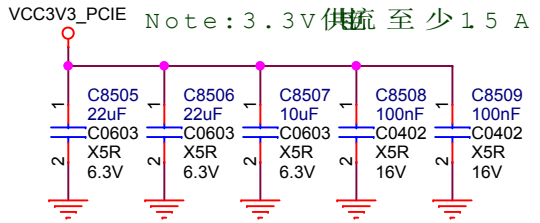
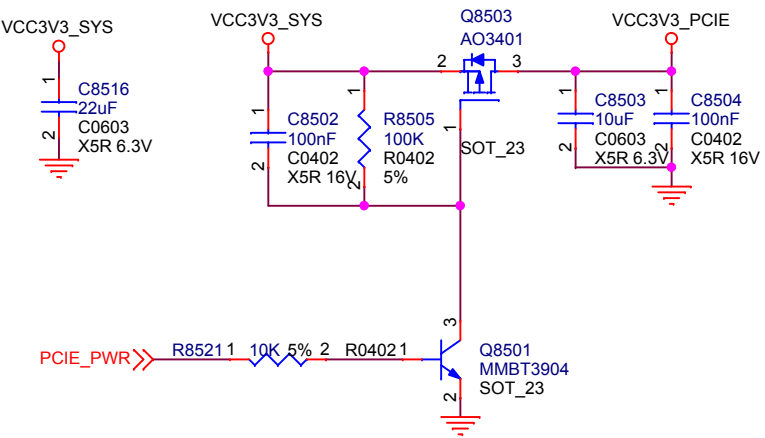
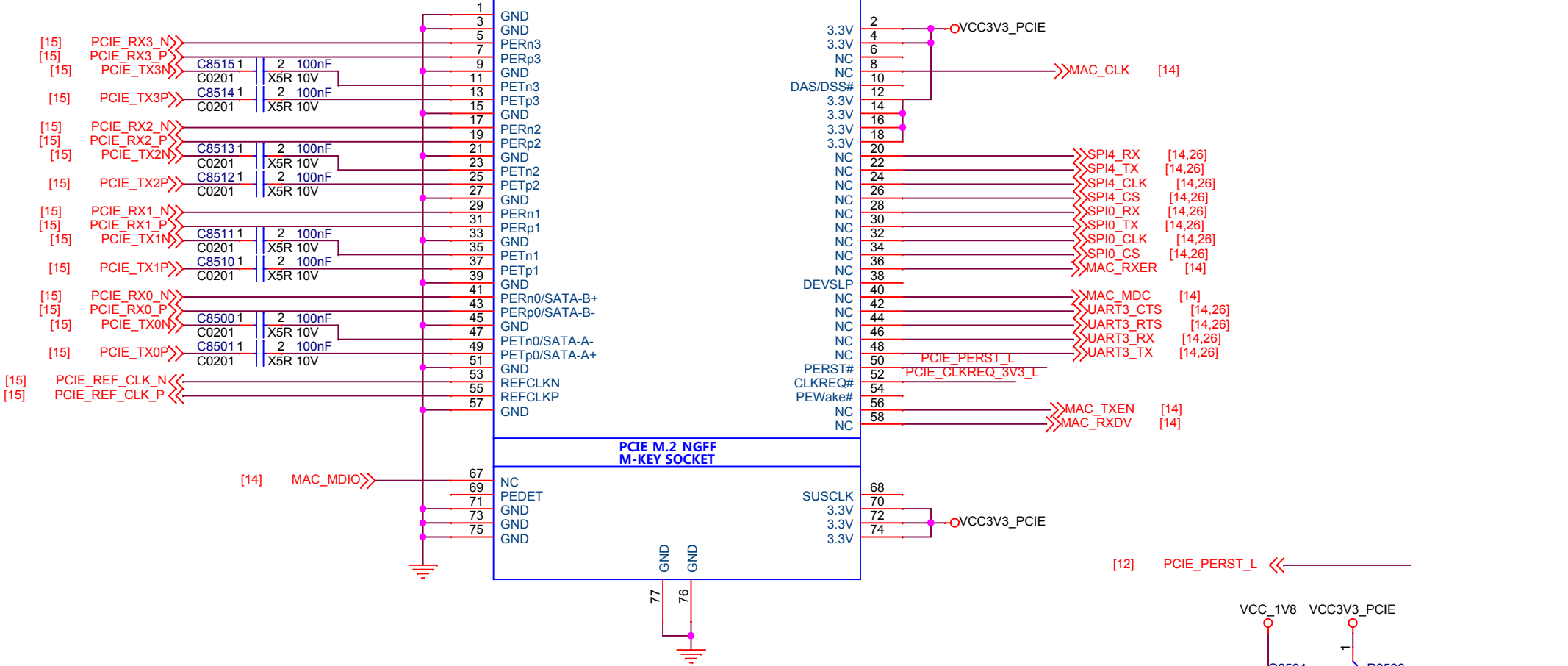

96rocks.com			
Project:	RK3399_ROCK960		
File:	<Page name>		
Date:	Thursday, April 05, 2018	Rev:	V1.0
Designed by:	<designer>	Sheet:	25 of 26

注意：
电压 VCCB >= VCC A。

